

## The Duffers' Guide to Valve Set fault finding – (part one).

By Graeme Wormald G3GGL

In the past ten years, since I've been active with E.U.G., I have had conversations with some members who have blinded me with rocket science and with others who didn't know what a local oscillator was.

As an entirely self-trained "technician", whose only "qualification" is an old-fashioned City & Guilds Pass in the Radio Amateurs' Exam of 1949, my approach to old valve radios is a very subjective one, entirely devoid of high-tech explanations and based only on experience.

"Lighthouse" magazine, during its 14 years of life, has published very many specific fault problems found in Eddystone models. Some of these are unique to certain sets or groups of sets but many are generic. It is this latter group which I am highlighting in this mini-series of fault-finding for the Duffer. By "Duffer" I don't make any derogatory reference, merely to target those such as myself who, for reasons diverse, never took a trade or professional course in radio or electronic engineering

I would first advise members to read "Electronic Repairs to Eddystone Receivers" by Peter Lankshear, a six-part feature which started in "Lighthouse" Issue 68, August 2001 and was completed in Issue 75, October 2002. (Available from me in two CD-ROMs (Vols 10 and 11) price £10 incl p&p.)

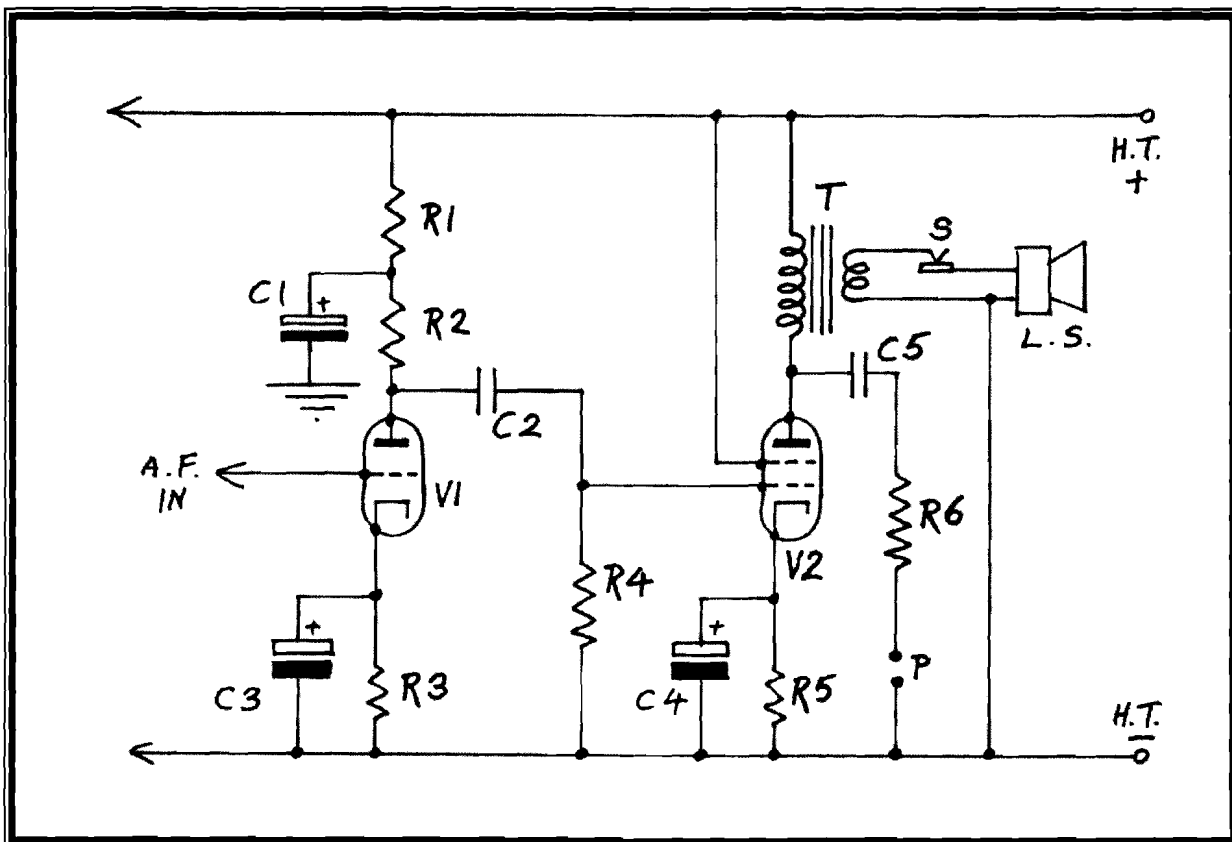

All radio problem-finding starts at the loudspeaker and works its way back to the aerial, so I have started with a basic circuit of the last (audio frequency) stages of an average receiver. It isn't based on any specific model and leaves out all the "trimmings", but it is sufficient to show most areas of concern.

I shall describe the functions of each item in simple terms and concentrate on the risk assessment as we go.

V1 is the first audio amplifier and it works on a low level of signal derived straight from the detector, be that signal AM, FM, SSB or CW. It will almost certainly be a multiple valve, such as a double triode, a double diode triode, or, in many cases of the Eddystone AC/DC models, a diode pentode. This doesn't affect the present approach. Take no notice of the other contents of the envelope.

The signal is fed into the control grid via a network of components which are not under consideration at this stage. It comes out at the anode after being amplified by a factor of anything between ten and a hundred, depending on sundry factors which don't concern us here.

The components surrounding it have the following functions:-

R1 is a decoupling resistor to reduce the possibility of audio instability. It is typically of a value between 5k and 50k ohms. It rarely gives trouble unless it is provoked by the short circuit failure of C1 in which case it will almost certainly have caught fire.

C1 is the decoupling condenser for R1. It is usually an electrolytic having a value between 2 and 8 mfd (microfarads) and a working voltage of about 350v.

As with all old electrolytics it must be treated with suspicion. If in doubt, the neon leakage tester should be applied (*see Appendix*).

This takes us now to R2, which is the "load" resistor of V1. It "forces" the amplified signal through C2 to the control grid (input) of the power stage (V2). It is typically between 200k and 500k ohms and is a very common source of trouble. Its value frequently increases by any figure up to infinity (i.e. open circuit). It is readily checked with the high ohms range of most multi-meters.

R3 is the auto-bias resistor, typically between 100 and 1000 ohms. It rarely gives trouble and may be readily checked both for value and for operating voltage shown in the table in the handbook using the multimeter.

*(To digress a moment; the reason it is described as auto-bias is that in the early days of wireless, grid-bias was provided by a small battery. The use of a cathode resistor with indirectly heated valves was termed "auto" and it stuck.)*

C3 is the cathode decoupling condenser and is typically 25 to 50 mfd at a working voltage of 25 to 50 v. Being an electrolytic it is also suspect, but difficult to check due to its low working voltage. It will rarely go short circuit, thus giving itself away by

multimeter test. As replacements are very readily and cheaply available (due to their common use in transistor circuitry) it is possible to make a good case for routine replacement.

Normally the replacement of a component without proof that it is the cause of a fault is to be deprecated, but this is an acceptable exception.

C2 is the "coupling" condenser between the anode of V1 and the control grid of V2. Its purpose is to stop the high voltage present on the anode of V1 (anything from 20 to 100 volts) from reaching the control grid of V2, which should be at a potential of several volts *BELOW* H.T. negative (i.e. less than earth).

C2 is a very common cause of fault, varying between distorted audio in the speaker to catastrophic destruction of the whole of the output stage circuitry.

Should there be *ANY* leakage whatever through C2 it will put a certain amount of positive bias on the control grid of V2. This in turn will cause the valve to draw more current from the high tension supply.

As this is already a power stage taking from about 20 to 50 milliamps it soon starts to get hot under the collar. But let us pause just there and describe the circuitry around this output stage, or what a former generation would have called "the loudspeaker valve".

R4 is called the "grid leak" and its purpose is to maintain a steady negative D.C. bias on the control grid with respect to the cathode. Its value is typically 100k to 1 megohm and is

not very critical; it rarely gives trouble. But if it goes open circuit there will be appreciable distortion in the set's output. This must be born in mind, however unlikely.

C4 and R5 are the auto-bias components for the output stage, V2, and do exactly the same job as R3 and C3 do for V1 (*Look back*).

"T" is the output transformer and has a step-down ratio of (about) 40:1 so as to match the 3 ohm impedance of a moving-coil speaker to the several thousand ohms output impedance of the output stage. The actual speaker itself may or may not be incorporated within the set, depending on the model. This makes no difference to fault-finding.

C5 and R6 represent the "padding" components of the high-impedance headphone arrangements. C5 is an H.T. blocker and is typically somewhere between 0.01 and 0.1 mfd's with a working voltage of about 350 v. R6 reduces the audio power being put to the headphones to stop your head being blown off. Its value will be of the order of 50k ohms.

"P" represents the headphone connections on the output jack. "S" represents the switch contacts which open to mute the speaker when headphones are plugged in.

C5 may become leaky and pass current when headphones are in use. Not a common occurrence but worth keeping in mind. A much more common occurrence is a complete loss of audio after headphones have been

unplugged.

This is usually due to a small foreign body (*the proverbial dead fly*) falling between the contacts of "S" and keeping the circuit open. It is usually cured by repeated rapid insertion of the headphones jack plug, and/or blowing and squirting with switch cleaner.

Returning now to the question of H.T. leakage through C2. This usually starts off as the merest hint of leakage which causes so little distortion that it isn't noticed. As time passes and it gets worse the output valve V2 will start to take more H.T. current which, in turn, will help to counter the problem to a degree.

This is due to R5 trying to create more negative bias, but the stage will take more and more current, causing R5 to overheat and the primary of the output transformer "T" to do likewise. Either of these could burn out, giving silence. A more likely occurrence is a ruined valve. It is essential that C2 be changed at once if there is the slightest hint of this problem.

Once again this is a case where it is worth changing without proof positive, (which can only be confirmed by the use of a neon leakage tester). I would urge any member who aspires to repairing old valve sets to have one to hand. (*See appendix.*)

A source of modern high voltage 0.01 to 0.1 mfd condensers must be found even before you think of opening an old valve radio. John Birkett of Lincoln always carries stocks at rallies. They

can be acquired brand new from Maplin, RS, and other catalogue dealers; some of them quite "small" operations. A mender of old valve sets needs to hunt around.

One other thing; get the set's handbook and check out all the valve electrode voltages as given in the table. Use a 20,000 ohms per volt analogue multimeter, easy to obtain these days. The figures quoted in the table are not gospel, but look for the wild errors.

To sum up: by far the most common faults in the area we have looked at (*in my humble experience*) are R2 going very high and C2 leaking badly.

In our next issue I shall look at the circuit details of the average RF/IF amplifier.

## APPENDIX

In the "Eddystone User Group Newsletter" (*as "Lighthouse" was then called*) Issue No 34, December 1995, pages 6 & 7, there appears an article entitled "Condenser Zapper".

In it I described the construction and use of a simple neon condenser tester and electrolytic re-former. It is worth its weight in gold when working on an old valve set, especially an Eddystone!

It is available from me, G3GGL, as an archive print of the article, for £1 coin taped onto a card – see inside front cover for QTH. Overseas members may send a bill in their own currency for sufficient to cover postage.



# The Duffers' Guide to Valve Set Fault-finding – (part two).

By Graeme Wormald G3GGL

In our last Issue I explained the philosophy behind this mini-series. How, in the past ten years, since I've been active with E.U.G., I've met members who could recite Ladner & Stoner backwards and others who'd never heard of A.G.C.

As an entirely self-trained "technician", whose only "qualification" is an old-fashioned City & Guilds Pass in the Radio Amateurs' Exam of 1949, I fall somewhere between these two extremes and my approach to old valve radios is a very subjective one, entirely devoid of high-tech explanations and based only on experience and reading.

"Lighthouse" magazine, during its 14 years of life, has published very many fault problems found in Eddystone models. Some of these are unique to certain sets or groups of sets but many are generic. It is this latter group which I am highlighting. By "Duffer" I don't make any derogatory reference, merely to target those such as myself who, for reasons diverse, never took a trade or professional course in radio or electronic engineering. Our last issue concentrated on the audio side of things; now we consider IF/RF amplifiers.

I would advise members first to read "Electronic Repairs to Eddystone Receivers" by Peter Lankshear, a six-part feature which started in "Lighthouse" Issue 68, August 2001 and was completed in Issue 75, October 2002. (Available from me in two CD-ROMs (Vols 10 and 11) price £10 incl p&p.)

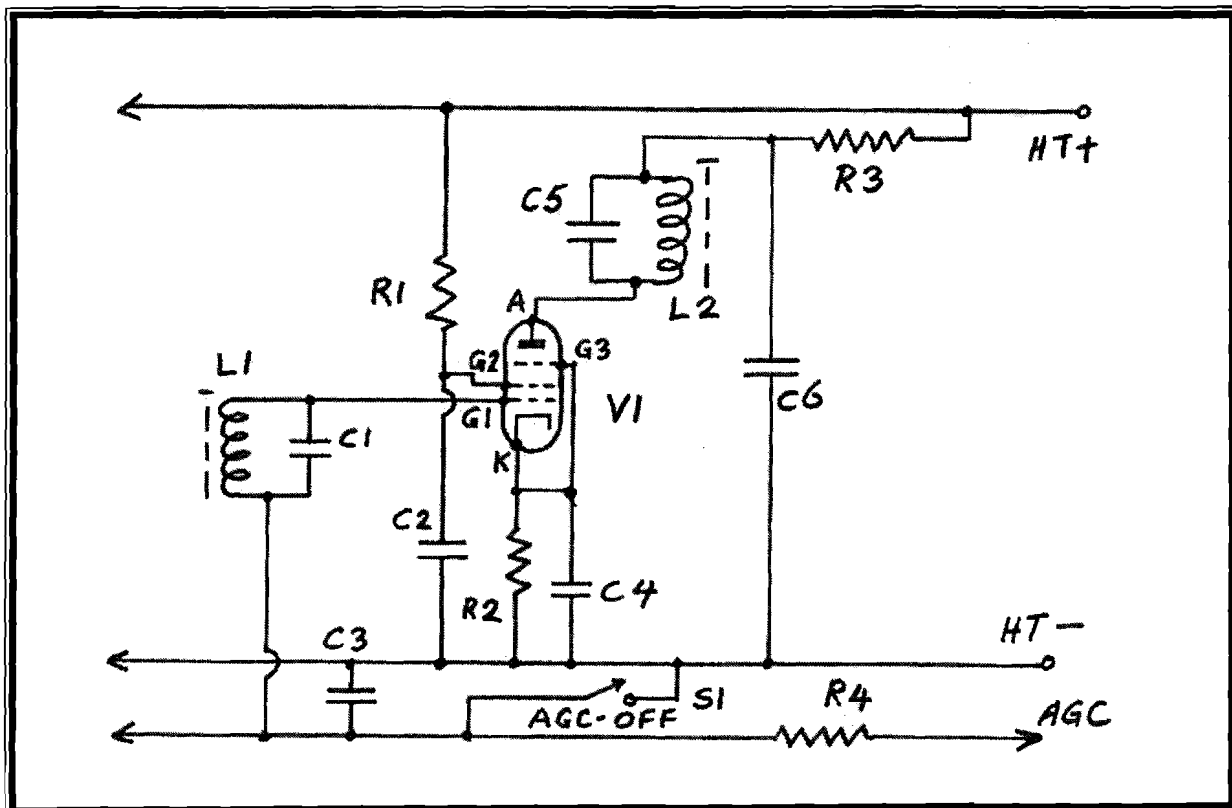

## HIGH FREQUENCIES

Our circuit this month shows a pentode (V1) arranged as a class 'A' voltage radio frequency amplifier; a universal condition for all such arrangements.

With the exception of the 'cascode' amplifier (an acronym derived from 'cascaded triode') all post-war general coverage receivers use pentodes for this job. Remember that signal frequencies and intermediate frequencies both count as radio frequencies, and may therefore be considered as one at this stage of the debate.

For the purpose of this article I have shown the circuit as an I.F. amplifier, but only to simplify the tuning arrangements. A five-band coil-pack would confuse the rest of the circuit where most faults occur.

## TYPICAL CIRCUIT

So let's analyse the circuit and highlight possible problems. L1/C1 represents the secondary of an intermediate frequency transformer (I.F.T.). L1 is typically a pi-wound inductor similar to a medium wave tuning coil. It is usually trimmed by a ferrite core threaded through the centre. The coil is resonated by C1, typically a silvered mica condenser of a hundred or so pico-farrads capacity.

It may be that the roles are reversed and C1 is a pre-set trimmer and L1 has no core. Should we be considering a signal frequency stage, both L1 and C1 will be adjustable and in addition the variable tuning condenser will be in parallel with the coil (although one end will of course be connected direct to

chassis earth).

The top (or 'hot') end of L1/C1 is connected direct to the control grid (G1). A much-amplified signal then appears at the anode (A) and is tuned by an identical circuit, this time consisting of L2/C5. This is shown as the primary of an I.F.T. and could well be followed by another stage which is virtually identical to the one shown.

Let us now consider the rest of the components.

## THE SCREEN GRID

The screen grid (G2) requires a steady supply of HT, the precise voltage being according to the design characteristics of V1, but supplied via R1 which is typically from 20,000 to 100,000 ohms in value. This is decoupled to earth by C2, typically 0.05 mfd., 350 volts working.

Both these components are common sources of trouble. R1 may go high in value or even open circuit. C2 frequently goes leaky, thus reducing further the voltage at G2. Gain will suffer. Special attention should be paid to the test voltage quoted for G2.

## THE CATHODE

The cathode (K) is connected to earth via an auto-bias resistor (R2), in exactly the same fashion as the audio stages shown in part one. The value will typically be from 100 to 1000 ohms. The decoupling condenser C4 will be around 0.05 mfd. These components rarely cause trouble. Even a leaky C4 is of little or no account as the voltage involved is very small (3 – 4 volts).

### THE ANODE or PLATE

The high tension (H.T.) is fed to the anode (A) via the decoupling resistor (R3), typically 1000 ohms and the R.F. return is made via the decoupling condenser C6 (typically 0.05 mfd.). This is also prone to leakage but the relatively low value of R3 will give no clue on the voltage check unless the leakage is very severe, in which case smoke will have been made! Check the body of R3 for discoloration due to overheating.

### GRID BIAS

Next we come to the arrangements for biasing the control grid (G1). The vast majority of valves used in high frequency amplification in a general coverage (or hamband) receiver will use valves which are described as variable-mu (pronounced 'mew'). This is actually a letter of the Greek alphabet ( $\mu$  = mu) which is used to symbolise 'gain'. It is also used, confusingly, to mean 'micro', one millionth part, as in 'micro-farad' ( $\mu$ F).

The gain of such a valve is controlled by varying the grid-bias, both automatically (as shown here) or by a variable potentiometer (not yet covered).

### AUTOMATIC GAIN CONTROL

The standing bias will be looked after by the cathode-bias resistor, R2, but Automatic Gain Control (A.G.C., sometimes referred to as automatic volume control – A.V.C., an archaic term) is universal in such radios.

This is generated in the same part of the circuit as the detector and will be

covered in a later episode. Suffice to say that a negative voltage is generated (typically 1-10 volts) depending on the strength of the received signal. This is fed back to the preceding stages via R4, a high value resistor, typically 200,000 to 500,000 ohms, and applied to the control grid, effectively in series with the standing bias. The R.F. return to earth is via C3. (Typically 0.05 mfd.)

The effect is to reduce the gain in such a way that strong stations sound hardly any louder than weak transmissions.

However, A.G.C. is really only desired for amplitude modulated material and Morse operation is much more satisfactory without it. In this case the A.G.C. can be disabled by shorting it out of circuit by the switch S1. The signal level is then controlled more effectively by the R.F. gain with the A.F. gain kept high.

### PRODUCT DETECTOR

S.S.B. reception on some later valve sets is accommodated by a special detector (known as a 'product detector', which will be dealt with in a future issue). In this case A.G.C. may be used with it, but without this device S.S.B. should be treated like C.W. and controlled with the R.F. gain as low as possible.

C3, however, is a very common cause of trouble. Any leakage whatever will reduce the available A.G.C. voltage, causing overload on strong stations when the R.F. gain is fully up. This manifests itself readily in the loudspeaker. Strong signals grate badly, weak ones sound normal. This

is a sure sign of a leaking C3. The same effect will occur with an open circuit R4, but this is far less common.

Sets with a beat frequency oscillator (B.F.O.) often combine this switch with the A.G.C. (S1). The Eddystone 840-series are examples.

Sets without a B.F.O. (such as the Eddystone 670-series and 870-series cabin broadcast sets) don't have the facility to disable the A.G.C. There is no need.

### TUNED CIRCUITS

Faults in these will show up as (a) great loss of sensitivity and (b) inability to peak the cores when aligning. Possibilities to look for include the following:-

Change in value of C1 and C5. These may go short circuit due to migration of silver round the edge of the mica. The coil screening-can will need to be removed and one end of the condenser isolated. A continuity test will then show a problem or otherwise. They may also go open circuit, usually due to a break or dry soldered joint at one end. Again the screening-can must be removed and the fault will usually be found by close visual inspection.

Another problem is a break in the coil L1 or L2. This can occur due to the dreaded 'green spot'. This is an acid corrosion at the point where the wire is soldered to the wiring 'frame'. (This is usually 'Litz' wire, a form of multiple insulated 'flex' having very good high frequency characteristics.)

This problem will have manifested

itself by lack of DC continuity through the circuit and is easily confirmed in the case of L2 by there being no voltage on the anode of V1.

In the case of L1 a simple continuity check will reveal all.

### DECOUPLING CONDENSERS

Leaky decoupling condensers are well-understood and have been referred to under their appropriate headings.

What is not so common and is often overlooked is a decoupling condenser going open circuit which will not show up in the normal voltage tests.

In the case of C3 and C6 the peak of their associated cores/trimmers will be very flat if present at all. Gain will be down. In the case of C2 instability may manifest itself. In the case of C4 gain will be reduced by a modest amount.

The only way to confirm any such suspicion is to isolate one end of the condenser and apply a capacity bridge or a direct-reading capacity meter. (One or both of these items is an essential part of any vintage Eddystone servicing workshop).

I have on two occasions found 'red Hunts' 0.05 mfd decouplers to have a capacity less than one thousandth of that figure (50 pico-farrads). One was in a 940 and the other an 830/7. The effect was virtually to disable the sets completely. And there are a lot of 'red Hunts' about!

Don't forget that 'Golden Age' Eddystones have lots of spare gain and are well-made. A deaf Eddystone is a sick Eddystone. ♠



# The Duffers' Guide to Valve Set Fault-finding – (part two).

By Graeme Wormald G3GGL

In our last Issue I explained the philosophy behind this mini-series. How, in the past ten years, since I've been active with E.U.G., I've met members who could recite Ladner & Stoner backwards and others who'd never heard of A.G.C.

As an entirely self-trained "technician", whose only "qualification" is an old-fashioned City & Guilds Pass in the Radio Amateurs' Exam of 1949, I fall somewhere between these two extremes and my approach to old valve radios is a very subjective one, entirely devoid of high-tech explanations and based only on experience and reading.

"Lighthouse" magazine, during its 14 years of life, has published very many fault problems found in Eddystone models. Some of these are unique to certain sets or groups of sets but many are generic. It is this latter group which I am highlighting. By "Duffer" I don't make any derogatory reference, merely to target those such as myself who, for reasons diverse, never took a trade or professional course in radio or electronic engineering. Our last issue concentrated on the audio side of things; now we consider IF/RF amplifiers.

I would advise members first to read "Electronic Repairs to Eddystone Receivers" by Peter Lankshear, a six-part feature which started in "Lighthouse" Issue 68, August 2001 and was completed in Issue 75, October 2002. (Available from me in two CD-ROMs (Vols 10 and 11) price £10 incl p&p.)

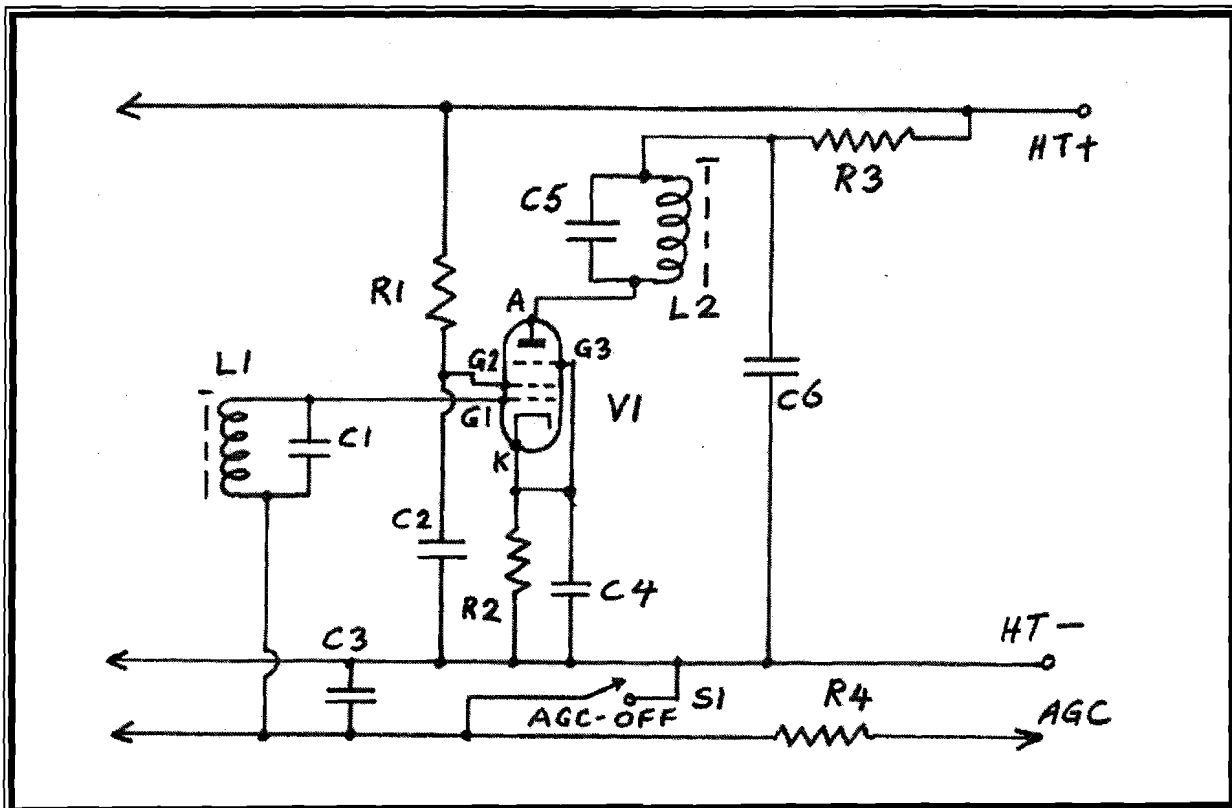

## HIGH FREQUENCIES

Our circuit this month shows a pentode (V1) arranged as a class 'A' voltage radio frequency amplifier; a universal condition for all such arrangements.

With the exception of the 'cascode' amplifier (an acronym derived from 'cascaded triode') all post-war general coverage receivers use pentodes for this job. Remember that signal frequencies and intermediate frequencies both count as radio frequencies, and may therefore be considered as one at this stage of the debate.

For the purpose of this article I have shown the circuit as an I.F. amplifier, but only to simplify the tuning arrangements. A five-band coil-pack would confuse the rest of the circuit where most faults occur.

## TYPICAL CIRCUIT

So let's analyse the circuit and highlight possible problems. L1/C1 represents the secondary of an intermediate frequency transformer (I.F.T.). L1 is typically a pi-wound inductor similar to a medium wave tuning coil. It is usually trimmed by a ferrite core threaded through the centre. The coil is resonated by C1, typically a silvered mica condenser of a hundred or so pico-farrads capacity.

It may be that the roles are reversed and C1 is a pre-set trimmer and L1 has no core. Should we be considering a signal frequency stage, both L1 and C1 will be adjustable and in addition the variable tuning condenser will be in parallel with the coil (although one end will of course be connected direct to

chassis earth).

The top (or 'hot') end of L1/C1 is connected direct to the control grid (G1). A much-amplified signal then appears at the anode (A) and is tuned by an identical circuit, this time consisting of L2/C5. This is shown as the primary of an I.F.T. and could well be followed by another stage which is virtually identical to the one shown.

Let us now consider the rest of the components.

## THE SCREEN GRID

The screen grid (G2) requires a steady supply of HT, the precise voltage being according to the design characteristics of V1, but supplied via R1 which is typically from 20,000 to 100,000 ohms in value. This is decoupled to earth by C2, typically 0.05 mfd., 350 volts working.

Both these components are common sources of trouble. R1 may go high in value or even open circuit. C2 frequently goes leaky, thus reducing further the voltage at G2. Gain will suffer. Special attention should be paid to the test voltage quoted for G2.

## THE CATHODE

The cathode (K) is connected to earth via an auto-bias resistor (R2), in exactly the same fashion as the audio stages shown in part one. The value will typically be from 100 to 1000 ohms. The decoupling condenser C4 will be around 0.05 mfd. These components rarely cause trouble. Even a leaky C4 is of little or no account as the voltage involved is very small (3 – 4 volts).

## THE ANODE or PLATE

The high tension (H.T.) is fed to the anode (A) via the decoupling resistor (R3), typically 1000 ohms and the R.F. return is made via the decoupling condenser C6 (typically 0.05 mfd.). This is also prone to leakage but the relatively low value of R3 will give no clue on the voltage check unless the leakage is very severe, in which case smoke will have been made! Check the body of R3 for discoloration due to overheating.

## GRID BIAS

Next we come to the arrangements for biasing the control grid (G1). The vast majority of valves used in high frequency amplification in a general coverage (or hamband) receiver will use valves which are described as variable-mu (pronounced 'mew'). This is actually a letter of the Greek alphabet ( $\mu$  = mu) which is used to symbolise 'gain'. It is also used, confusingly, to mean 'micro', one millionth part, as in 'micro-farad' ( $\mu$ F).

The gain of such a valve is controlled by varying the grid-bias, both automatically (as shown here) or by a variable potentiometer (not yet covered).

## AUTOMATIC GAIN CONTROL

The standing bias will be looked after by the cathode-bias resistor, R2, but Automatic Gain Control (A.G.C., sometimes referred to as automatic volume control – A.V.C., an archaic term) is universal in such radios.

This is generated in the same part of the circuit as the detector and will be

covered in a later episode. Suffice to say that a negative voltage is generated (typically 1-10 volts) depending on the strength of the received signal. This is fed back to the preceding stages via R4, a high value resistor, typically 200,000 to 500,000 ohms, and applied to the control grid, effectively in series with the standing bias. The R.F. return to earth is via C3. (Typically 0.05 mfd.)

The effect is to reduce the gain in such a way that strong stations sound hardly any louder than weak transmissions.

However, A.G.C. is really only desired for amplitude modulated material and Morse operation is much more satisfactory without it. In this case the A.G.C. can be disabled by shorting it out of circuit by the switch S1. The signal level is then controlled more effectively by the R.F. gain with the A.F. gain kept high.

## PRODUCT DETECTOR

S.S.B. reception on some later valve sets is accommodated by a special detector (known as a 'product detector', which will be dealt with in a future issue). In this case A.G.C. may be used with it, but without this device S.S.B. should be treated like C.W. and controlled with the R.F. gain as low as possible.

C3, however, is a very common cause of trouble. Any leakage whatever will reduce the available A.G.C. voltage, causing overload on strong stations when the R.F. gain is fully up. This manifests itself readily in the loudspeaker. Strong signals grate badly, weak ones sound normal. This

is a sure sign of a leaking C3. The same effect will occur with an open circuit R4, but this is far less common.

Sets with a beat frequency oscillator (B.F.O.) often combine this switch with the A.G.C. (S1). The Eddystone 840-series are examples.

Sets without a B.F.O. (such as the Eddystone 670-series and 870-series cabin broadcast sets) don't have the facility to disable the A.G.C. There is no need.

### TUNED CIRCUITS

Faults in these will show up as (a) great loss of sensitivity and (b) inability to peak the cores when aligning. Possibilities to look for include the following:-

Change in value of C1 and C5. These may go short circuit due to migration of silver round the edge of the mica. The coil screening-can will need to be removed and one end of the condenser isolated. A continuity test will then show a problem or otherwise. They may also go open circuit, usually due to a break or dry soldered joint at one end. Again the screening-can must be removed and the fault will usually be found by close visual inspection.

Another problem is a break in the coil L1 or L2. This can occur due to the dreaded 'green spot'. This is an acid corrosion at the point where the wire is soldered to the wiring 'frame'. (This is usually 'Litz' wire, a form of multiple insulated 'flex' having very good high frequency characteristics.)

This problem will have manifested

itself by lack of DC continuity through the circuit and is easily confirmed in the case of L2 by there being no voltage on the anode of V1.

In the case of L1 a simple continuity check will reveal all.

### DECOUPLING CONDENSERS

Leaky decoupling condensers are well-understood and have been referred to under their appropriate headings.

What is not so common and is often overlooked is a decoupling condenser going open circuit which will not show up in the normal voltage tests.

In the case of C3 and C6 the peak of their associated cores/trimmers will be very flat if present at all. Gain will be down. In the case of C2 instability may manifest itself. In the case of C4 gain will be reduced by a modest amount.

The only way to confirm any such suspicion is to isolate one end of the condenser and apply a capacity bridge or a direct-reading capacity meter. (One or both of these items is an essential part of any vintage Eddystone servicing workshop).

I have on two occasions found 'red Hunts' 0.05 mfd decouplers to have a capacity less than one thousandth of that figure (50 pico-farrads). One was in a 940 and the other an 830/7. The effect was virtually to disable the sets completely. And there are a lot of 'red Hunts' about!

Don't forget that 'Golden Age' Eddystones have lots of spare gain and are well-made. A deaf Eddystone is a sick Eddystone. ♠

## ***The Duffers' Guide to Valve Set Fault-finding – (part three).***

***By Graeme Wormald G3GGL***

It has been very gratifying to receive positive feedback in recent weeks from members who are finding this series a help in their understanding of valve sets. There are many people, and I'm one of them, who are incapable of following any mathematical or academic explanation of radio-related technology.

In spite of having worked as a technician/engineer in the broadcast industry from the age of 21 for eight years, and ending up as a "senior master control engineer" (yes, that was my official designation), I "flew by the seat of my pants". In fact, that was the only formal professional qualification I ever acquired, courtesy of the Korean War. The rest of my technical background is entirely self-taught, starting with my ham ticket whilst at school. The result is that I always interpret technology in an entirely empirical manner.

This means that I can express myself in such a manner, and though a conventionally trained and qualified technician or engineer will smile and nod wisely (he knows the real answer to what I'm waffling about), a lot of folk find it works for them too.

For the record, at the eighth year (above) I realised that I could no longer bluff my way through life as an "engineer" with such a shaky foundation. I quit engineering and moved into presentation directing, a job which I had learned by watching others. I had two day's training and stayed in the discipline for the remaining 31 years of my working life.

In the meantime I enjoyed "mucking about" with old radio technology which became older as I did!

This month we're going to look at mains power supplies or P.S.U.s. I should really have started with this subject because if you have no power you've no set to service, but somehow that escaped my mind at the time.

I must also ask readers to excuse my tendency to mention things which should have been mentioned weeks before, but this series is very much written as you go. If done properly it would probably amount to 1,500 pages – the size of Langford-Smith's "Radio Designer's Handbook".

I doubt if I should live long enough and I think, dear reader, that you would have died of boredom in the meantime. So having wasted a page on platitudes may I remind you to check the introductory advice to Parts One and Two, and then read on . . .

## CURRENT FLOW

I don't think we've gone into this before. We should have, but we didn't. Better late than never.

In the dim and distant past of the 19<sup>th</sup> century, when electricity was a mysterious and wonderful "substance" (*isn't it still?*), scientists and dabblers were presented with something which seemed to "flow" in a conductor.

Electricity was an "abstract substance", unlike, say, water which can be detected and followed by the human senses of sight and touch. But it **was** discovered that if an electric "current" flowed through a wire it would deflect a nearby magnetised needle, but they had no way of knowing which way it was "flowing". (Note the analogy with liquid in all this terminology.)

So they guessed. And they guessed wrong.

They decided that the carbon in a Leclanché Cell was positive (+) and the zinc was negative (-). (A Leclanché Cell was a very early version of our carbon/zinc 'dry' battery).

And they based all the laws of electricity and magnetism on this, such as Fleming's right hand rule screw rule (which I don't intend to go into here!).

But we're stuck with it and you might ask "Why?"

Well the reason is that electricity is based on the presence of electrons in atoms. And these are negative by the above convention.

That is to say that when you switch your flashlight on, the electricity actually flows from the negative end to the positive end of your battery via the filament of the bulb.

This is a trick to confuse those of us

with tidy, logical minds. And we're stuck with it. Not that it matters when we're talking about flashlights or even car headlamps but what about radio?

OK, then. Let's take a diode, the simplest of all thermionic valves. (Thermionic, by the way, means the emission of electrons from something hot.)

The simplest diode consists of a vacuum-filled low-voltage electric lamp bulb with a plate above the filament connected by a sealed wire to a terminal outside the lamp.

This plate is called an anode, which is why our American cousins call the anode a plate. (*More confusion*).

If you connect a battery of, say, 20 volts, from one side of the glowing filament to the plate lead, with the negative (-) pole of the battery going to the plate, no current will flow.

If you turn it the other way round a measurable current will flow, apparently from the plate to the filament. ***BUT WE KNOW THAT THE ELECTRONS, (i.e. THE CURRENT) ARE BEING EMITTED FROM THE FILAMENT.***

This means that all our natural instinct of assuming the high tension positive is flowing from the plate (anode) to the filament (cathode) is proved wrong.

The current goes out from the hot cathode in every form of radio valve and is "sucked up" by the HT (positive) connected to the anode.

This is unnatural to our logic but nevertheless this is what is happening.

If no HT is present the current (i.e. electrons) just fall back into the cathode, except for a few which end up stuck to the glass, which is why you see a silvery deposit inside a very old panel lamp in your vintage Eddystone

receiver.

Now we seem to have spent a long time going round the houses to get to this point, but a clear understanding of the above basic principle is essential to a comprehension of valve radio.

It also makes it much easier to follow on with the bit about P.S.U.s, which is where this entire article started.

First of all may I make it very clear that there are two kinds of mains power

units which are used in Eddystone receivers. The first is the AC-only and the second is the "universal" AC/DC type.

We shall start off with the AC-only variety because this is used on all the better sets and some folk condemn the "universal" sets as "rubbish". However, there was a good reason for their presence in the Eddystone range at the time, but we shall discover that further down the column.

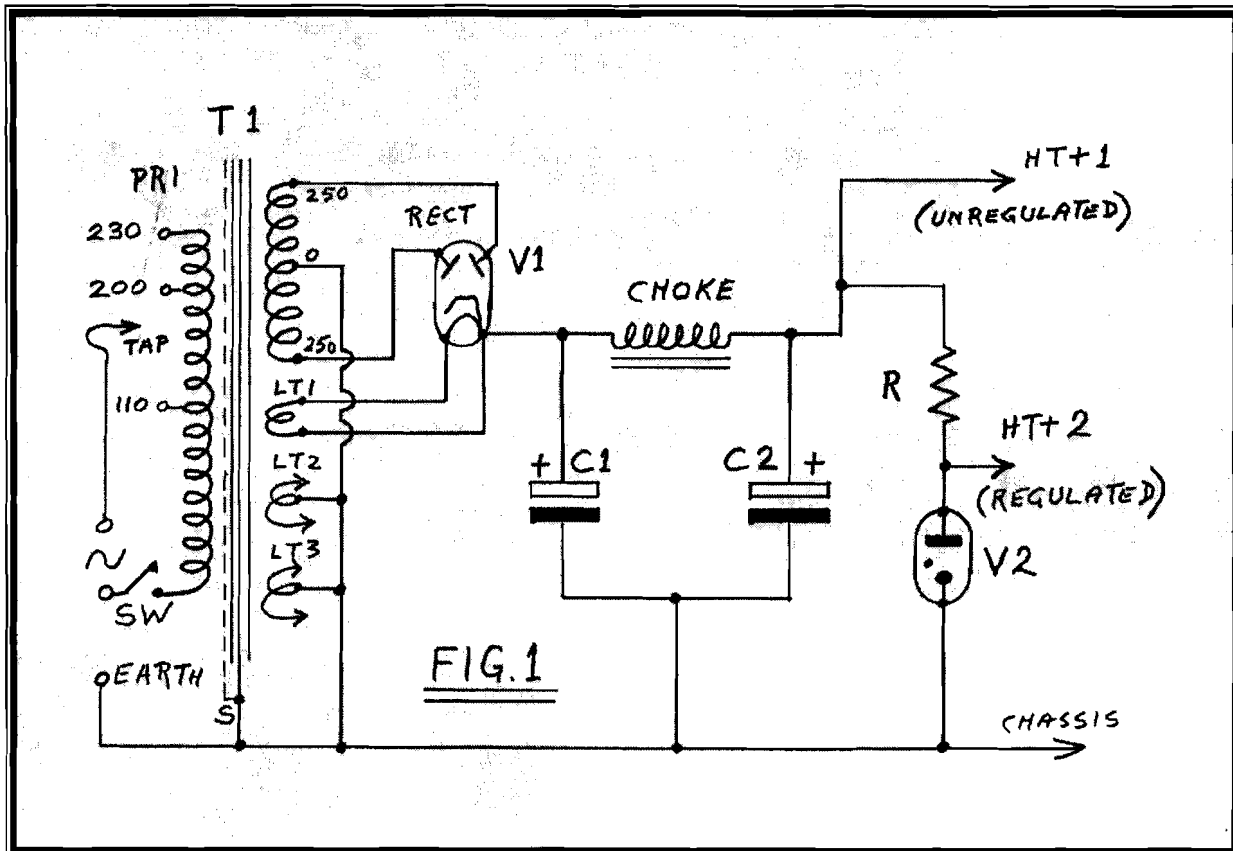

Consider now the above Fig. 1. It is the circuit of the power supply for a typical "upper class" Eddystone valve radio. We shall discuss every part of it starting from the little squiggle at the left hand side which represents the AC mains input.

On sets up to the early sixties this input connector was not polarised nor did it have a mains earth connection. In fact, on the first post-war models it wasn't even a connector; it was hard-

wired into the set. (At least they had a mains earth and correct polarity!)

The mains earth here has to be taken to the terminal adjacent the aerial connectors. The mains switch is single pole in some sets, double pole in others (i.e. a switch in each leg of the mains.) Some sets had fuses here, some didn't. Whatever the arrangement it is unlikely to cause trouble other than mechanical failure. Sets from the mid 'sixties onwards

used a polarised twin plus earth connector which is well-nigh impossible to obtain. It can be replicated by clever mechanics using parts of other connectors, but this isn't the place to explain that.

The advice I always give to those with a connector-less Eddystone is to remove the existing chassis connector and tape it inside the frame to be restored when the correct "mate" is found for it (this might take years). Then install a three way tag-strip and hard-wire the mains into it. There's nothing wrong with that; 99% of modern appliances are so wired.

The little arrow head marked "TAP" is a plug or screw link to select the appropriate mains input to the primary winding of the transformer. In Europe and other 230 volt countries this is most important to check.

110v is for our Canadian and American cousins only. The result of 230v at this point will double the voltages on all the secondaries and saturate the iron core of the transformer. Every conceivable disaster is imminent. The only question is "where will the fire start?"

The DC resistance of the whole of the primary, as measured on the AVO (or whatever) is low, of the order of 10-20 ohms. The most likely source of trouble is an open circuit (obvious) or shorted turn(s). In the former case the set will be dead. In the latter case the set may work and the fault remain "dormant" for a period until it finally burns out (which it will).

The owner has no control over either of these disasters. The only cure is a professional rewind which will probably cost about £100. It might be cheaper to acquire a rough Eddystone with a good transformer and cannibalise it. On close inspection many "similar" Eddystones are found to use the same transformer. (i.e. different sets of the

same era.)

This is one of the more serious reasons that a non-worker should be viewed with suspicion. If the valves don't light up our problem is in this area. On the other hand it may only be a faulty mains switch, in which case the AVO will reveal all.

I don't intend to go into the theory of mains transformers. It is complicated and may be read up in a suitable text book. Suffice to know what it does.

The three vertical lines up the middle of "T1" represent the soft iron stampings of which the core is constructed. The dotted line to the left of them is a screen separating the mains primary winding from the supply secondaries. This is to reduce the transfer of QRN from the mains into the set. It is always earthed. The core is also earthed but, as each lamination is magnetically isolated from its brothers it may well be electrically isolated from earth. This doesn't concern us.

But the reason that the core of a transformer is composed of laminations (and not just a lump of iron) is to stop eddy-currents being induced into the core. This would cause massive losses and overheating.

Now let us progress to the right-hand side of the vertical lines. Here you will see four separate windings. Starting at the bottom we have LT3. This is a 6.3 volt centre-tapped low tension winding used by Eddystone for the noise-limiter and S-meter double diode. The reason for this eccentricity has become clouded in the mists of time, but when you come across it that's what it's for. It's not always used. The centre tap is earthed so as to minimise hum pickup from the heater wiring.

LT2 is exactly the same except that it is of a much higher current rating,



because it feeds all the rest of the valves in the set.

LT1 is a special isolated 5 volt supply for the HT rectifier valve. The vast majority of octal valve rectifiers have 5 volt heaters, some taking 2 amps, some taking 3. Some have indirectly heated cathodes (as shown here). Some are directly heated. This need not concern us as the same pin is always used for HT plus output.

One set springs to mind as being different in this area. One octal valve, the 6X5, which is used in the S.640 has a 6 volt heater. This was developed for use in 6-volt battery sets and presumably there was a glut of them in 1947! The cathode is not only indirectly heated but also heavily insulated from the heater as there will be full HT voltage between them. Again, this point is academic to us here and is only mentioned to complete the picture.

Continuing up the secondary windings we come to a 500 volt winding with a centre tap, labelled 250-0-250. This is the high tension winding and is commonly called a "full wave centre tap rectifier circuit". It is more properly called a "bi-phase rectifier circuit" but let's not worry too much about terminology. Most people just call it "full wave".

I haven't mentioned it before so I'd better mention it now. All the AC voltage references we have made are voltage R.M.S. That means "Root mean squared" and is easiest interpreted as "average". Remember that AC power is not a straight line like DC, it is a sine-wave. I think we'd better have a little picture here to make

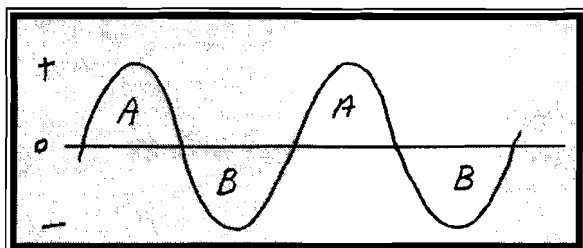

it clearer.

This is a normal AC voltage wave-form as put into the primary of the mains transformer. It is also exactly the wave-form which comes out of the secondaries.

Now let us consider the situation with respect to V1, the power rectifier. This is a double diode with a common cathode. It has the above waveform fed into its two anodes but from the opposite ends of a centre-tapped winding.

When the upper end of the winding is positive, current will flow through the right-hand anode (or plate). No current can flow through the left-hand anode because it is negative with respect to the cathode.

When the polarity reverses the current will then flow through the left hand anode (but not the right-hand) and the resulting output from the cathode will look like this:-

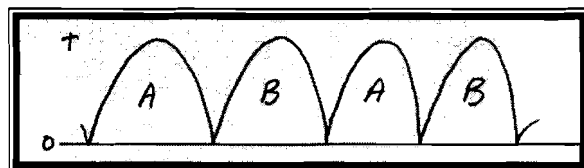

It is called raw rectified AC and once upon a time it was used to feed a power oscillator (1920's) to provide modulated CW giving a 100 cycle note from 50 cycle mains. That was outlawed so now we turn it into pure DC by the next stage.

C1 is the first Smoothing Condenser (or capacitor in modernspeak). It is called the reservoir condenser because it takes a charge when the above waveform peaks positive and gives it out to fill in the gaps. It is typically of a value of 8 to 32 microfarads with a working voltage of 450 volts. It takes a lot of strain and must be in first-class condition to do its

job properly. It will be of the variety known as "electrolytic" because anything else would be the size of a house-brick! Electrolytic condensers are "polarised", that is to say that they have a positive and negative terminal, the correct connection of which is essential. The result of error will be explosion.

At this stage the use of a "Condenser Zapper" is highly advised (see Part One, Issue 86, August 2004).

The voltage at the + end of C1 would look like this:-

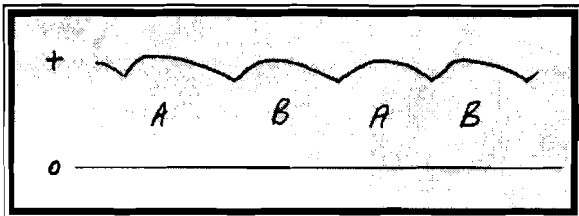

A bit of a ripple, but shaping up. It's then fed into the Choke, commonly called the Smoothing Choke and it's very aptly named. It is typically rated at 10 Henries, 100 milliamps.

Consider it to be like one hole of a spaghetti maker. The mixture goes in crooked but comes out as straight as a die and Bingo! You have smooth DC.

No need to draw a picture of this waveform, it's a straight line. The voltage will depend to a large degree on the load taken, which in an Eddystone might be anywhere from 60 to 100 milliamps.

But there is one small addition necessary to finish the recipe. The HT rail (as it is now called) needs decoupling to earth, just the same as circuits in previous episodes.

Another condenser, C2, is provided here and to differentiate it from C1 it is called (yes, you've guessed) the Decoupling Condenser. The value is usually the same or greater than the reservoir condenser and, of course, it's

another electrolytic.

Many sets (such as the 640 and 740) leave the HT supply at that but the real professional (and ham-band) sets use an extra stage called a "regulator".

This makes use of an interesting phenomenon found in certain rare and inert gasses such as neon or argon.

When a sealed tube with two electrodes inserted is filled with the gas at a very low pressure it is able to create a voltage drop across these electrodes which is stable to a fraction of a volt in (say) 100 volts.

This property is harnessed in a simple circuit called a shunt regulator.

In Fig.1 this is shown by V2, commonly called a neon stabiliser or regulator. Its design factors determine its operating conditions and a typical specification would be 150 volts at 30 milliamps. This means that if it were fed from a higher voltage source via a resistor (in this case "R") it would produce a steady voltage (HT+2) of 150 whilst the load varied between zero and 30 milliamps. This is more than ample to feed two or three oscillators in the typical communications receiver.

V2 is known as a "Cold Cathode" tube as it has no heater and relies on the principle of ionised gas for its operation. The "dot" shown in the "envelope" indicates that it is gas-filled.

The value of "R" is typically 5,000 ohms, 5 watts, wire wound.

I did intend to carry on and describe the details of the "Universal AC/DC" power supply used in many popular Eddystone models intended for use in particular on board ship, where, fifty years ago the available power was invariably 110 volts DC. But I think I've stretched your attention quite enough for one article. We shall continue in Part Four. ♠

# The Duffers' Guide to Valve Set Fault-finding – (part four).

By Graeme Wormald G3GGL

I had promised to be sufficiently advanced in my writing of this little saga to be covering the principles of oscillation by this stage. Regretfully, writing in my truly amateur style I have fallen well behind. I apologise; I shall catch up one way or another.

Last month we covered the standard type of 'A.C.' power supply unit (p.s.u.) and I had intended to describe the 'universal' type of AC/DC p.s.u. at the same time, but we over-ran (as I suspect we may well do now!).

I'll just remind readers that I'm writing for those quite unacquainted with electrical theory, and who just pick up amateur radio as they go along (as I did). So here goes with the counterpart to last issue's episode.

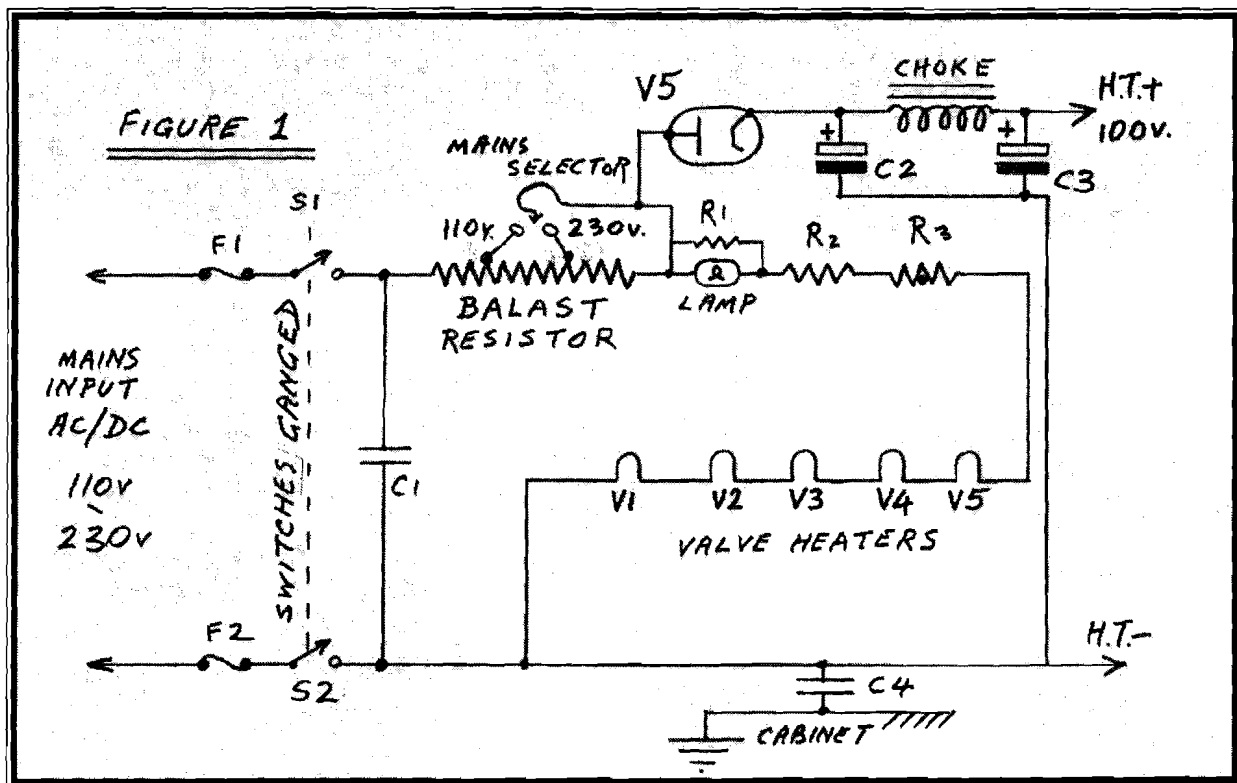

It might well help to have last month's "Guide" before you as you read this. Every section has its counterpart although this circuit looks rather more complex!

## PHILOSOPHY

There are two reasons to design a receiver which will work off both AC and DC mains. The first is to have a set that will actually work off AC as well as DC supplies! The second (mark this well) is to save manufacturing costs.

So, you may ask, why bother with AC-only sets if they are both less flexible and more expensive? Fair enough. But there is one over-riding answer. Reliability. In general terms an AC-only set is much more reliable than the so-called "Universal" or AC/DC model.

Ask any old-time service engineer. He will tell you that valves last longer in an AC-only set and that you have far more trouble with ballast resistors and thermistors than with mains transformers. OK then, so why did Eddystone ever get mixed up in AC/DC sets when their motto was "Quality"?

The answer is very simple. By the time Eddystone produced their first AC/DC set (the S.670 in 1948) AC mains were rapidly spreading throughout the world, at least they were in places likely to be investing in Eddystone radios.

The answer lay in places with no mains at all. I'm referring, of course, to merchant shipping. Even such wonders of the seven seas as the "Queen Mary" were running off 110 volts Direct Current. And had been doing since before the "Titanic".

All these Universal Eddystones were aimed primarily at the seafarer. The land-based customer was a secondary (but very welcome) issue.

Hitherto, the vast majority of universal

sets had been of the 'cheap and cheerful' variety. Unfortunately, over the years, Eddystone has become 'guilty by association'. But in fact the opposite was true. Eddystones were probably the best Universal sets built in the world. Certainly letters from satisfied customers, still standing on the company's files, would indicate so:-

*J.K.Andrews, wrote from India in 1961:*

**"I have had my Eddystone 670 Marine Receiver for 13 years now and have been more than satisfied with its excellent performance in all conditions"**

## A LOOK AT THE DETAILS

So let's examine the circuit of Figure 1 and analyse the role of each section. Remember that this is not a specific set, merely typical of the *genre*. If you can follow this circuit then you'll be able to follow any other AC/DC power unit and make allowance accordingly.

The mains goes in at the left hand side and in all Eddystone sets the chassis, which is connected to one side of the mains (hopefully the 'neutral') is isolated from the metal case and all accessible metalwork. **But once out of the case it is lethal, even when the chassis is 'neutral'**. There are too many points of high voltage floating about.

At this stage may I point out that any radioman dealing with valve sets, especially 'universal' sets, should own a traditional electrician's screwdriver. These are still commonly sold.

It is a 5- or 6-inch long instrument-type of screwdriver completely insulated except for the last half-inch at the blade end. The handle is transparent and may be clear or yellow.

Within the handle is a small neon lamp and resistor connected at one end to the blade and at the other end to a small metal disc at the top of the

handle.

It may be used as a screwdriver in the normal way (it was originally produced for repairing wire fuse blocks). For testing the polarity of power mains the blade is touched onto the terminal or metalwork to be tested. A finger is then placed on the top disc, thus creating a very high impedance capacitive return to earth through the body (i.e. 'neutral'). It is quite safe, painless and without 'sensation'.

If the blade is touching a part of similar potential then nothing will be observed. But should it be touching a part at 'line' potential (often wrongly – but graphically – called 'live'), then the neon lamp in the handle will glow quite clearly and you are warned.

If you're reading 'Lighthouse' and don't have such a simple life-saver, go right out NOW to your nearest hardware shop and get one. They cost about £1.

Never work on a 'universal' receiver without one to hand. If the chassis is found to be live then change the power leads over at once.

The two fuses (when fitted) will be rated at about 250–500 milliamps, depending on the design of the set. The two-pole mains switch is usually ganged to the volume or tone control.

The condenser C1 is intended to reduce interference coming in on the mains. This is questionable, but what is not questionable is the likelihood of a vintage condenser to explode on being presented with 400 volts peak.

Yes, that's what 230 volts r.m.s. (*root mean squared*) standard AC mains is at the top of the sine-wave. If you find such a condenser get rid of it. Value typically 0.01 mfd. Don't bother to replace it unless you're a purist, and then use one rated at 1,000 volts.

The bottom line in the circuit is HT negative and in an Eddystone receiver

is isolated from the cabinet by C4, again typically 0.01 mfd. Replace this with a new similar one of 1,000 volts working. Don't mess about; we're talking about serious safety here.

The next most obvious item is the 'heater chain', which equates to the L.T. winding in an A.C.-only set. The requirement here is to illuminate all the heaters from a power source of 100 volts upwards.

In an AC-only set it is normal for all valves (except the rectifier) to use a heater voltage of 6.3, the required wattage being adjusted at design stage by varying the current consumption.

For instance, a normal voltage amplifier such as an RF pentode or detector commonly has a consumption of 0.3 amps ( $6.3 \times 0.3 = 1.9$  watts). A power output (loudspeaker) stage might have a consumption of 0.9 amps ( $6.3 \times 0.9 = 5.1$  watts). This is in order to provide the extra emission from the cathode to allow a heavier HT current to be drawn.

With a universal set the heater supply must be drawn direct from the mains supply so the common factor becomes current, not voltage. This means that valves requiring a greater emission have the same current as the rest of the valves but at a higher voltage.

The principle is just like old-fashioned Christmas tree lights where (for instance) 24 ten-volt lamps are wired in series across a 240-volt supply.

Unfortunately there were several different current standards of "universal" valve heaters, including 0.1 amps, 0.15 amps, 0.2 amps and 0.3 amps.

Of these, the latter was really intended for television use and the 0.2 was a series which was never used by Eddystone in AC/DC sets. The two first standards were widely used.

At 0.1 amps, for instance a normal RF stage might be rated at 14 volts (1.4 watts), whereas an output stage might be rated at 45 volts (4.5 watts).

There is one limitation, however, and that is the requirement to operate on a mains (or ship's) supply of no more than 100v. Add up all the stages for a communications receiver (don't forget the rectifier is a power valve!) and it will soon pass the 110-volt mark.

To digress here for a moment, the history of successful universal sets is very much that of the American midget of the 1930s-40s. Take a standard 4-valve plus rectifier superhet.

The first three valves (I suppose I should say 'tubes' in this context!) are standard 6.3 volt, 0.3 amp types, but with the heaters modified to operate on 12.6 volts at 0.15 amps. That makes 38 volts when in series. Take a 35-volt heater rectifier and a 50-volt output valve and count on your fingers.

That makes 123 volts, which is (was?) the standard North American domestic supply. No coincidence! Dead easy. But we old-worlders have a problem in logistics. What do you do with the other hundred-odd volts?

There's only one answer, I'm afraid. Throw them away by putting a series dropping resistor in the heater chain. Commonly called a ballast resistor, it is a chunky wire-wound device more suited to central heating than radio technology.

So for typical values we need to refer to the set design. Are they 0.1 amp heaters (670 series)? Or 0.15 amps (870 series)? Or do they fall into the trap of adding up to over 110v and have to be wired in series-parallel (840 series)?

What a nightmare! I think we'll keep away from those details and look at the circuit again. The ballast resistor is

quite clear to see. It is invariably in the 'top' end of the chain and feeds the anode of the rectifier also.

When operating on a DC supply the rectifier is doing nothing, just passing a smooth flow of current, but don't forget that if the supply polarity is reversed (easily done) then no high tension will reach the set even though the heaters are glowing. A diode cannot conduct 'backwards'.

Let us now continue down the rectifier route. Presented at the anode when run on an AC supply there will appear the classical AC sine wave voltage.

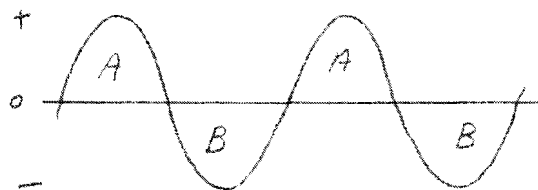

The positive half-cycles are labelled 'A' and the negative ones 'B'. Being only a half-wave rectifier there is nowhere for the negative half-cycle to go. It is completely suppressed. Appearing at the cathode of V5 will be the following VERY lumpy DC waveform.

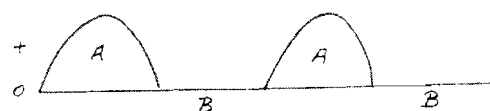

This goes straight into the reservoir condenser, C2 (compare with part three of this series) which has to work very hard for a living. The modified waveform which then enters the smoothing choke looks like this:-

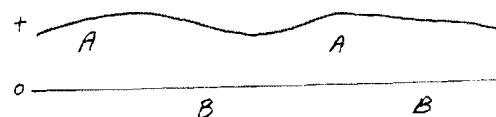

After it's gone through the choke and been decoupled by C3 it will be a straight line, just the same as in the AC bi-phase (full-wave) circuit of last month. But the three smoothing

components (C2, C3 and the choke) have all contributed a little extra to achieve it. That's why a weakness (reduced capacity) in either of the smoothing condensers is readily detected by a 50-cycle hum in the loudspeaker. In a full-wave circuit any hum due to poor smoothing will be a 100-cycle note. Remember that!

So having acquired an HT supply of around 100-volts let's go back to the heater chain which has some extra (as yet) unexplained components.

First of all let's take the lamp (or lamps, there may be more than one of them, still in series). If it were just in series with the heaters any failure of the lamp filament would spell death to the set. It would effectively switch itself off by removing the low tension.

Some sets *are* like that, but a sensible designer would make it a 'fail safe' condition by building in a hefty shunt resistor across the lamp, shown here as R1. Again, the values will depend on the (variable) design parameters, but let's make some up for an example.

Let us say the valve heater chain is 0.15 amp and the pilot lamp is 3.5-volts. It is normal practice to under-run such lamps so a 0.2 amp filament would be typical. A value for R1 of 20 ohms would be reasonable, allowing about 2 volts to appear on the lamp. (Note that this is a very inexact calculation; the resistance of an under-run lamp is a good bit lower than a fully run one, but it serves to illustrate.)

Should the lamp filament blow then the whole of the heater current would flow through R1 giving a voltage drop of three instead of two. This would have no effect on the operation of the set; it just wouldn't have its pilot light showing.

R1 would be a wire-wound item of about one watt.

Moving now on to the next item in the chain, R2. Strictly speaking it has no purpose whatever; it is merely adding a little more voltage drop to that obtained by the ballast resistor. But so many Eddystone models incorporate it that I thought I should alert people to it.

It is wire-wound, about 50 ohms and rated at six watts. I can only think that it is to adjust the heater drop from an otherwise stock value of ballast dropper. It will only drop about five or ten volts in any case and I must admit to being slightly baffled!

Next in line is R3, shown as a resistor with a black dot in the centre. This represents a patent device called a "Thermistor". It is sometimes depicted as a zig-zag resistor in a little oblong box. Same thing.

A thermistor is a negative co-efficient resistor. Most conductors increase their resistance when they heat up. A thermistor reduces its resistance when it warms up. Typically, when cold, it will be of several hundred ohms. After reaching operating temperature this will fall to about 40 ohms. It usually takes two or three minutes to do this.

The philosophy behind this device goes thus: the valve heaters in such a radio will be of a disparate nature, as already explained. This means that during the warm-up period some valves reach operating temperature before others.

The result is that, because the resistance of the cooler heaters is still reduced, the current through the warm heaters is increased and therefore the voltage is increased. (Ohm's Law.) The life of these temporarily over-run valves will therefore be reduced. (This is one of the reasons why 'universal' sets are less reliable than AC-only.)

The presence of a thermistor reduces this risk and is incorporated into all such Eddystone sets. Very few cheap

universal sets incorporate them; they just have a little extra resistance in the dropper.

They came into their own with the advent of mass television with a huge string of 0.3 amp heater valves in series and ready to give trouble at the drop of a hat! They were worth their weight in gold to the pre-solid state television owner.

Now never having being involved with the domestic repair business I know very little about these thermistors. They are no longer made and are virtually unobtainable. They were made in different ratings, viz. 0.1 amp, 0.15 amp, etc. etc. and they had reference numbers such as CZ1, CZ2, CZ3, which mean nothing to me.

They look like black one-watt carbon resistors and I've never seen one with any markings on it, even new. I presume they were supplied in labelled packets! I am quite often asked by members where they can obtain such devices for their Eddystones.

I've only once seen them advertised

recently, and I don't know the amps rating, but try "BOWOOD ELECTRONICS", tel: 01246 583777 and ask them. One is "THM001 rated at 300Ω cold and 24Ω cold; or THM002 rated at 1000Ω cold and 90Ω hot. Price 30p each. P&P £1.50

My other answer is to replace the thermistor with a normal wire-wound resistor of the same value as the thermistor would be when hot. If the value isn't given on the circuit (it is on some but not others) then it is easy to work out using Ohm's Law on the rest of the given values.

OK, you're probably reducing the life of some of the valves by a few hundred hours in several thousand, so what the hell! (Even the famous and long-lived Bush DAC90A didn't use a thermistor.)

I've one last thing to say about Figure 1. I apologise for spelling 'ballast' with only one 'l'. I've just noticed it but I'm blowed if I'm going to re-scan the whole darned lot!



---

**Is Your Eddystone sick, deaf or just plain not working?**

**Well don't give up on it.  
East Coast Wireless can repair, overhaul or fully restore  
your Eddystone as required.**

All models, valve or transistor, will receive the same loving care in our well-equipped workshop, ensuring that your Eddystone meets the original specification after repair.

East Coast Wireless currently repairs and restores vintage and classic radios, communications receivers and TVs from all over the British Isles.

**Why not join our band of satisfied customers!**

Please contact us for advice on requirements, costings etc. prior to any shipment to us.

**Speak to Graham Gosling on  
01945 780808  
2, Holt Court, Walpole St Peter  
WISBECH, CAMBS. PE14 7NY  
or e.mail us at - coastwire@aol.com**



# The Duffers' Guide to Valve Set Fault-finding – (part five).

By Graeme Wormald G3GGL

It has been very gratifying to receive positive feedback from members who are finding this series helps in their understanding of valve sets. There are many people, and I'm one of them, who are incapable of following any mathematical or academic explanation of radio-related technology. This has triggered Tor Marthinsen, our very academic Norwegian Correspondent, to react quite strongly to our last episode (AC/DC power supplies).

Tor is a fanatic for detail and made the point that **"THERMISTORS ARE THERE TO PROTECT THE PILOT LAMPS AND THE TUNING INDICATORS IN EDDYSTONES!! OTHERWISE THESE WILL BE DESTROYED . . . "**

I suggested to him that he put us wise with a treatise on the subject and he has done just that! You'll find it in this Issue a few pages hence.

In the meantime I'll try and give a few words about oscillators, as promised six months ago . . .

Discounting the requirements of transmitters, all post-war Eddystone valve receivers have at least one oscillator stage in them. Most have two and several have three.

For the record, they all have a "local oscillator" as part of the frequency-changer because they are all superhets. (We'll deal with that aspect in another Issue.)

Most of them have a beat-frequency oscillator to resolve Morse and S.S.B. and the double-superhets, such as the 750, 888, 830 and EA12, have another "second" local oscillator to change the first intermediate frequency into the second (or narrow-band) I.F.

But let's consider now the question of oscillation and how it happens.

If a triode valve is so arranged that its output circuit is coupled back to its input circuit, in such a way that the voltage applied to the grid is opposite

in phase to that which exists in the anode circuit, then the valve will operate as an oscillator.

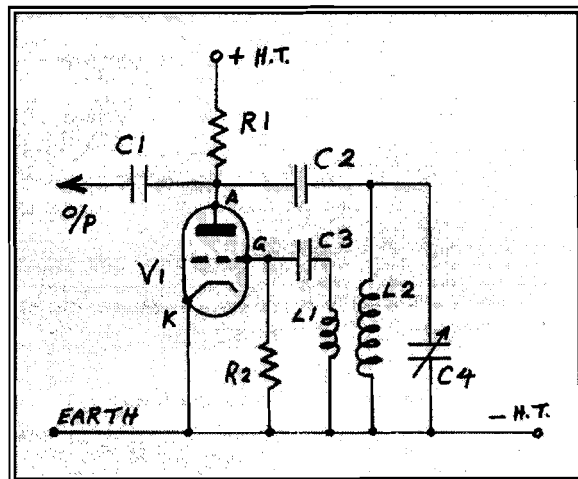

This means that it will generate an alternating voltage in the form of a sine-wave (i.e. 'radio waves' in our case), the frequency of which is determined by the circuit constants, that is to say the coil (L1) and condenser (C4).

The above circuit represents the basis of the majority of self-excited (i.e. free-running) valve oscillators that will be found in receivers. Let us consider it in detail piece by piece.

The valve, V1 is shown as a triode. There is no virtue in using a pentode for the job; the pentode was designed not to oscillate! If one is used it will usually be found to be strapped as a triode.

An oscillator is self-starting; that is to say that the tiniest impulse of "cosmic noise" (or whatever) appearing on the grid "G" will re-appear at the anode "A" magnified to a certain degree.

This impulse is blocked from reaching the H.T. (and hence to earth) by the load resistor R1 (typically 47k).

The output feed condenser, C1, is typically 10 pf and will be of higher impedance (i.e. high frequency resistance) than C2, (typically 100 pf). This condenser (C2) serves the purpose of stopping H.T. from shorting direct to earth via L2 but at the same time allowing the impulse to reach the resonant (tuned) circuit, L2 and C4.

This resonant circuit has the property of turning these "random" impulses into a sine wave, the frequency of which is determined by the value of these two components.

It actually occurs when the impedance of the coil L2 equals that of the condenser C4. The current flowing through each (and hence the voltage) is in opposite phase to precisely 180°. The resulting impedance is considerably greater than each separately and will have a magnifying effect on the sine wave.

An analogy can be made with a hard bat and a rubber ball being bounced on a hard floor. As long as the bat is coming down as the ball rises then an oscillation is maintained.

This sine wave is induced into the aperiodic coupling coil, L1, which transfers it through the grid condenser C3 (typical value 50 pf) onto the grid. The grid has zero static bias and when the sine wave goes positive then a D.C. current will flow, the circuit being completed by the grid leak, R2 (typically 22k).

The grid condenser (C3) will stop this negative voltage leaking away during the negative half-cycle from L1 and the oscillator therefore operates in Class "C"

There is, of course, a hell of a lot more to it than this, but you can go to the big books previously mentioned for that. The principal is established. It's like a Class "C" amplifier with grid leak bias being driven by its own output. As long as the current in the circuit is continually being replaced by the feed of H.T. via R1 it will keep on going.

## FAULTS

The condensers shown in this circuit will all be good quality silver-mica and should be reliable. Both R1 and R2 carry D.C. currents during their operating life and may therefore go high, but easily checked. The coils L1 and L2 (which are wound on the same former) are unlikely to fail unless they suffer from the dreaded "Green Spot", in which case they will have gone open circuit. The tuning condenser C4 will almost certainly be air-spaced and will last forever if kept dry and clean.

In addition, of course, there is likely to be a whole raft of wavechange switching and trimming devices which will be susceptible to dirt and damage. An aerosol tin of switch-cleaner should always be to hand.

In a further episode we will consider the actual use of oscillators in a radio receiver.



# The Duffers' Guide to Valve Set Fault-finding – (part six).

By Graeme Wormald G3GGL

In our last edition of "Duffers' Guide" we examined the nature of the variable oscillator and mentioned that every valve set made by Eddystone after WW2 used one as a "local oscillator". (*Actually there's a 'typo' on page 18 at the bottom of the RH column. For (L1) read (L2). Correct it now whilst it's in your mind.* Take another look at and let us consider the whole question of the "Frequency Changer".

By the mid 1930s the "Superhet" had become dominant among commercial receivers; but what does it mean? The word itself is a corruption of the term "supersonic heterodyne", the first word of which has actually been overtaken by events in current meaning, which is "faster than sound". In the early 20<sup>th</sup> Century, however, the word was used to mean "beyond sound", indicating radio frequencies.

"Heterodyne" refers to mixing two frequencies together thus producing the sum and the difference of these, but in our case it is only the difference which is of interest. The same principle is used by the musician to 'tune' an instrument with the help of a tuning fork. When the instrument is out of step with the fork, a low note equal to the difference in frequencies will be heard. The same effect is heard by the pilot of a twin-engined piston aircraft; a low droning pitch indicates that the engines aren't synchronised. One of the throttles will be adjusted until the drone gets less and then disappears.

So we are dealing with producing a third, usually fixed, frequency from the signal entering the set via the aerial.

The technology of "frequency changing" is complicated in the extreme and fills many columns in designers' handbooks but we shall take most of it as "read".

Our circuit illustrates the most common type of single-valve frequency changer which evolved out of many types in the 1930s and which will suffice to be analysed here.

The valve itself is a dual type, one half being the "mixer" (V1a). It has six electrodes, anode, cathode and four grids and is termed a "hexode".

The other half is a normal triode, as described in our last Issue. The whole valve is therefore described as a "triode-hexode". The special thing about this valve is that the two separate units are interconnected by a link between the control grid (G1) of the triode (V1b) and the "mixing grid" of the hexode (G3). This hexode actually has two screen-grids, connected internally, but no suppressor grid (as in a pentode RF amplifier).

Don't ask me why, because I've no idea. All I know is that the hexode

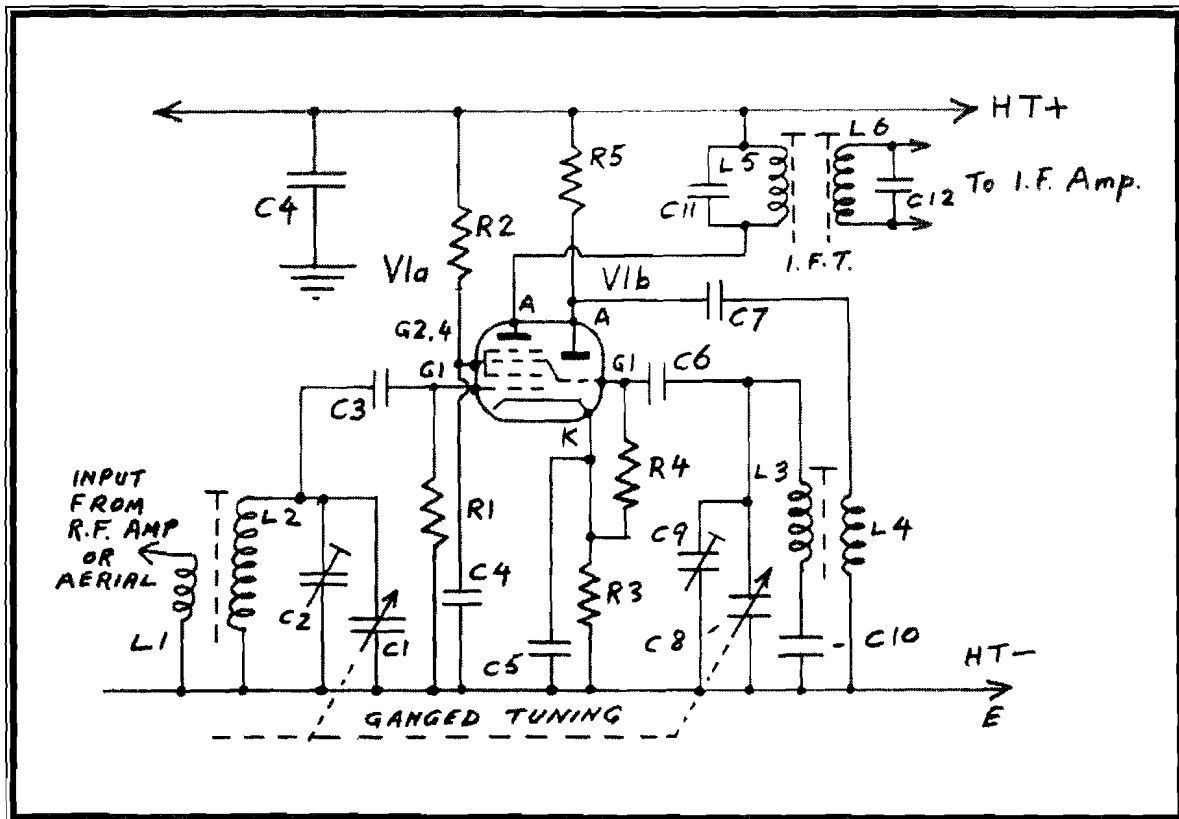

behaves like any other amplifying valve, but the signal being amplified is "modulated" by the oscillations from the triode. The effect is much akin to low-level amplitude modulation but with a higher modulating frequency, and one of the sidebands is selected in the anode circuit of the hexode. This is termed the "intermediate frequency" and, normally being fixed, is then easily amplified to any desired degree of selectivity. That is the secret of the superhet.

If you look back to "Part Two" of this series (Issue 87, October 2004), you will find a "universal radio frequency amplifier", which looks very much like the mixer part of our circuit and it operates in a similar manner, with similar trouble-spots. Have it beside you.

Let's start at the input end and go through each component. L1 is the aperiodic (untuned) coupling coil from the previous stage(s). In the simplest of all superhets this will be direct from the aerial.

Perhaps I should point out at this stage that all band-switching is ignored. It would make the analysis impossible to follow. But remember that on an Eddystone circuit you will need to find your way through the jungle of extra coils.

L2 is tuned to signal frequency by C1, part of the tuning gang. L2 has an iron-dust core and a pre-set trimmer, C2, both of which are used in the alignment procedure and then take no further active part in the operation.

The signal is fed to the control grid (G1) of the hexode (V1a) via condenser C3, typically 100pf, silvered mica. The grid is returned to earth (for standing bias) via R1 (typically 470k).

It looks like a leaky-grid detector, and, in fact, our North American cousins always call this stage "the first detector" (and the *real* detector is called "the second detector").

The cathode is common to both valves in the envelope and is returned to earth via R3 (a few hundred ohms) and

decoupled by C5 (typically 0.01 mfd). R3 generates the grid bias for V1a (but not V1b, see later).

Sometimes R1, the grid return, is fed to the AVC (AGC) line, but this is frowned upon for short-wave working as it may upset the stability of the local oscillator, V1b.

The screen-grids of the hexode (G2,4) are fed from the HT in the usual way via R2 (typically some tens of thousands of ohms) and decoupled by C4 (typically 0.01 mfd). I've just noticed that I've got two "C4"s. Sorry! They are both decoupling condensers and of similar values.

The desired intermediate frequency (IF) is selected at the anode of V1a by the primary of the first intermediate frequency transformer (IFT), L5 and C11. The former has an iron-dust core, used for adjusting the alignment, and the latter is usually silvered mica of a few hundred pico-farads.

So far we haven't mentioned the actual frequency of this newly acquired "intermediate frequency". In an ideal world it would be about 10% of signal frequency, but in a general coverage receiver working from (say) 150 kc/s to 30 Mc/s then a compromise must be made. Convention has decreed that a frequency of about half a megacycle is suitable. Different makers have their favourites but Eddystones usually operate on 450 kc/s.

It's probably best to mention one of the uglier sides of superhets at this point. This is known as "image" or "second channel" interference. As this explanation contains some simple arithmetic I'm going to assume an IF of 500 kc/s to avoid confusion.

In practice (for reasons which will become obvious later in the debate) the local oscillator (V1b) always operates on the high frequency side of signal frequency.

Let's assume we are tuned to a medium wave broadcast signal on 300 metres or 1,000 kc/s. The local oscillator will be running at 1,500 kc/s. The "image" will appear 500 kc/s above this, to wit 2,000 kc/s.

The pre-selection offered by L2/C1, the input tuned circuit, will have absolutely no problem in keeping this image out of the mixer grid, the difference in frequencies is 100%.

But let's go to the other extreme. We are listening for a bit of CW DX on ten metres and are tuned to 28,100 kc/s. The LO will be humming away at 28,600 kc/s and the image response (or "second channel") will be on 29,100 kc/s. Imagine that the band is wide open and the CQ-World-Wide SSB Contest is under way . . .

Poor old L2/C2 is having to separate signals less than 4% of frequency apart. And it can't do it. It will need a lot of help which is why any top-grade Eddystone (or anything else for that matter) will have two signal-frequency tuned circuits ahead of the mixer. Even then it has a hard job to sort the sheep from the goats and that's where we enter the territory of the double superhet. But not tonight, Josephine.

Now let us turn our attention to the actual circuitry of the local oscillator. You will find it virtually identical to that shown in last Issue's "Duffers' Guide." The reason that the grid leak (R4 in today's cct) is returned to the cathode of the valve and not earth is to avoid it being biased by the auto-bias resistor of V1b (R3). The actual tuned circuit is in the grid circuit of V1b instead of the anode circuit of last month. This is fairly academic and follows convention.

The one item which is unique to a superhet's local oscillator is C10, the "padding condenser". The reason for its presence goes like this: go back to the paragraph at the top of this

column. Let us assume (for the sake of simplicity) that the medium wave broadcast band which is being covered goes from a high frequency of 1,500 kc/s (200 metres) to a low frequency of 500 kc/s (600 metres).

This means that the mixer grid (and any previous stages of amplification) are covering a frequency ratio of 1,500/500 or 3 to 1.

The local oscillator will be covering a range of 2,000 kc/s (when the signal is 1,500) to 1,000 kc/s (when the signal is 500 kc/s). This means a frequency ratio of 2,000/1,000 or 2 to 1.

This is a difference which will not be accommodated by using the same value of variable condenser for C1 and C8. This condenser and its strays will typically cover the range 50pf to 500pf.

In the case of C8 it will only have to cover from (say) 40pf to 400pf over its 180 degree swing.

This condition is achieved by placing a "padding condenser" in series with C9, which is what, in effect, C10 is doing.

Its value "Xpf" will need to be calculated from the conventional formula for the value of condensers in series, C10 multiplied by C9, divided by C10 plus C9.

This will give an answer of something like 1,000pf and should be of the best quality silvered mica. It will, of course, be a different value for each waveband and will come in part of the bandswitching circuit.

So far in life I've never come across a set with a problem condenser in this area. Keep your fingers crossed and hope it will be the same for you. The values of these padding condensers in a circuit have to be accurate to less than 1% and they are all "special" (i.e. "odd") values. A replacement would almost certainly mean building one up from several selected smaller ones

and then putting a trimmer in to get it spot on.

Now I don't want anybody working it all out and telling me I've got the values all wrong. I've already explained that I'm a duffer too and I just don't "do" mathematics. For the purpose of illustration the figures will do

Anybody really wanting "the goods" had better look in "Langford-Smith".

The next pitfall for the unwary is the question of "tracking" on the higher bands. I've already explained that the local oscillator operates on the "high" side of signal frequency. This gives no problem on the bands up to, say, 4 mc/s.

But above this frequency, and getting progressively worse as we go up to the 30 mc/s limit of most general coverage receivers, there is a great risk of getting the oscillator *BELOW* the signal frequency at one end of the band, usually the HF end of the band.

When doing a full re-alignment of any general coverage set the concentration needed to pull everything into line, with the accompanying back and forth frequency setting, can addle the brain.

It's dead easy to set the LO high at 30 mc/s and low at 13 mc/s. I've even managed to do it on the next band down, getting the LO low at 12 mc/s and (correctly) high at 6 mc/s. The set behaved very oddly around 9 mc/s, believe me!

After many embarrassing episodes I've finally discovered the answer to this pitfall. Here it is . . .

You don't track the LO on the signal generator like the book says. You get a general coverage digital receiver and *LISTEN* to the LO on that. You know exactly where it should be and there's nothing easier. I use a "Lowe" HF 150 for the job.



# *The Duffers' Guide to Valve Set Fault-finding – (part seven).*

*By Graeme Wormald G3GGL*

We're now starting the second year of "Duffers' Guide", a mini-series which I expected to run for about four issues. It seems as though one subject automatically leads to another and you end up having covered the "Main Features" but with lots of loose ends floating about.

Remember that this column is about the blind leading the blind. I've never had a day's formal training in radio receivers. Having being a SWL and home-brewer since 1946 I acquired the RSGB handbook and persuaded my father to cough up for the ARRL handbook in 1948. I got my ham ticket in 1949 and never looked back. Apart from a course in BBC techniques at Wood Norton Hall in 1954, in which I failed dismally to grasp the significance of "Operator J", I've never had formal training in matters radio.

I realise that many of our members are similarly placed and that it is quite difficult to find information dealing with *OLD* valve receivers. That was the spur to this series and this month we'll pick up one of those loose ends.

It's another of those old-fashioned terms which dates from the nineteen thirties and then got magically changed by the meddlesome terminology brigade some time in the early 'sixties.

I'm referring to that essential adjunct to valve superhet receivers which I still call Automatic Volume Control, or AVC for short.

The terminology brigade then moved in and decided that on grounds of precise interpretation it should be referred to as Automatic Gain Control (AGC). For anybody wondering just what the difference is between the two I shall make it quite clear, here and now, that we're talking about the same thing. Exactly the same thing.

And what was good enough for the Eddystone 730/4 is good enough for me. I know. I'm looking at one now and it says "AVC" plain and simple.

There were three main reasons for the introduction of AVC.

The first was based on the massive increase in performance of radio

valves in the early 'thirties coupled with the near universal adoption of the superhet. At the same time broadcasters were increasing the power of their transmitters a hundredfold. A set capable of receiving weak DX would overload massively when tuned to a local signal.

Secondly, this offended the listeners' ears as they tuned from one end of the band to the other. All most unsatisfactory.

And thirdly, fading (QSB) on short waves can be most distracting. AVC reduces or even eliminates QSB.

So the notion was born that if a portion of the rectified (DC) carrier signal was fed back from the detector stage to earlier amplifiers it could be used to reduce some of the incoming signals and "smooth things out" when tuning.

The designers obligingly invented pentode valves that would change their amplification factor according to the DC bias applied to the control grid. The more negative the grid, the less

the amplification.

The technical term for amplification factor is the Greek letter  $\mu$ , pronounced "mew" and spelt in English "mu". Thus these valves were referred to as "variable-mu". Most of them had fixed-mu near-equivalents. For instance, the EF39 may be considered as a variable-mu version of the EF36. Likewise the 6K7G and the 6J7G. A good AVC circuit could typically reduce a strong signal by a factor of, say, 100.

At this point I'd better mention that another term for a "variable-mu" valve

is a "remote cut-off" valve. This refers to the fact that a fixed-mu valve may be biased to run at minus four volts and be completely "cut-off" i.e. not drawing any anode current, at minus ten volts. A remote cut-off valve will still be drawing some anode current at, say, minus 30 volts. This is to accommodate the negative AVC voltage and (when fitted) the negative voltage from the RF gain control.

However, let's accept all such details as read and examine a typical AVC and detector circuit.

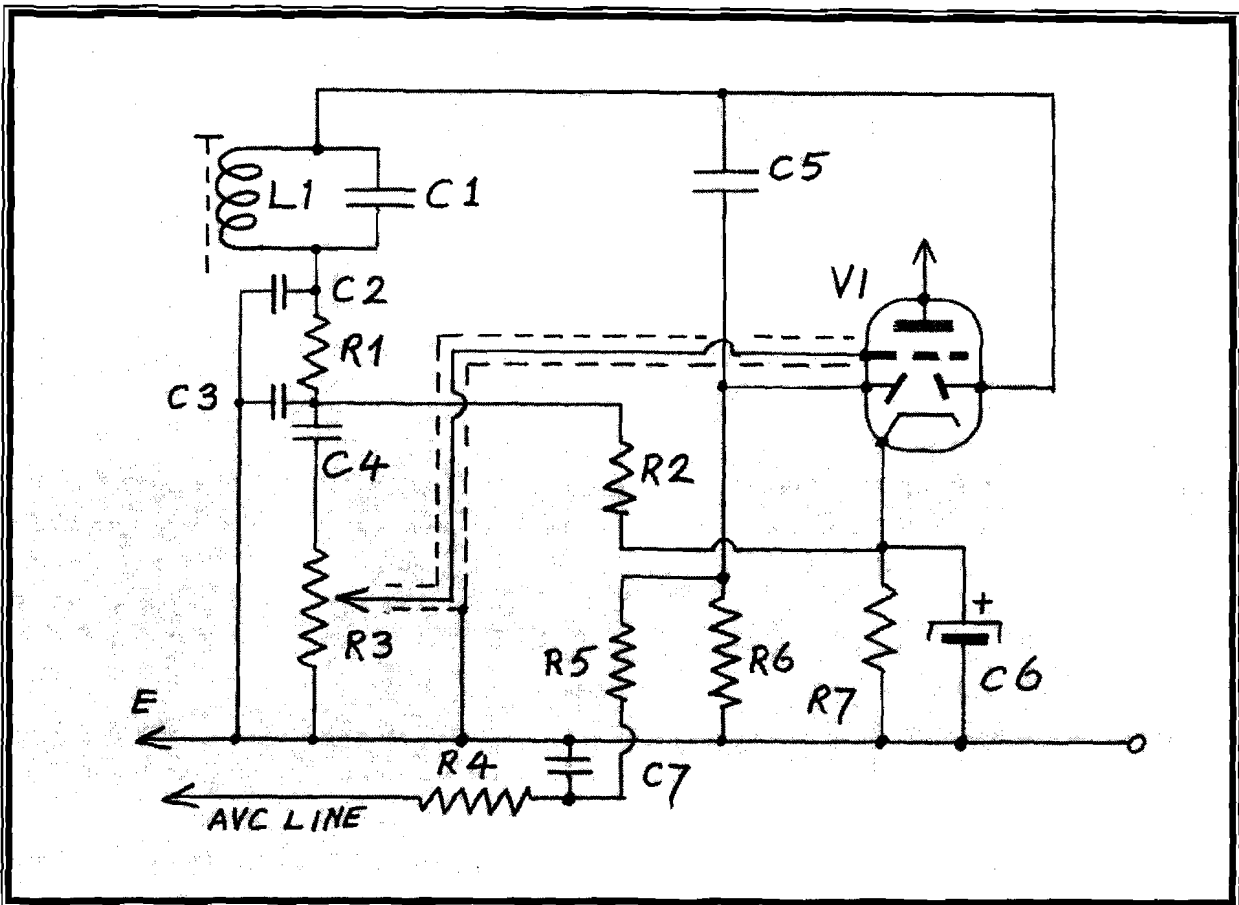

The above circuit is typical of a multiple valve known as a double-diode triode. It was pretty much established in this form by the mid nineteen-thirties and continued with little change until the end of the valve era in the late 'sixties. Let's examine it step by step.

The signal input appears on the

secondary of the final intermediate frequency transformer (IFT) which is shown as L1 and C1. It has acquired its signal from its own primary, which isn't shown here because it's irrelevant to this debate.

Forget about the microvolt and millivolt signals you're used to hearing about when RF is discussed. At this end of



the chain we're talking about VOLTS of RF, and more than one of them.

The value of C1 will typically be of the order of 100pF in a general coverage set having an intermediate frequency of about half a megacycle. It will almost certainly be silvered mica. Once the core of L1 has been tuned to resonance it should be a fairly reliable component.

As with all IFTs the only likely faults are mechanical by nature. There may be a break in the fine wire of L1 or there may be a short in the silver of C1. Silver has been known to migrate to the edge of the mica and short to the other side. This is uncommon but can happen to any silvered mica condenser. Don't overlook it.

I'd better mention the nature of the wire in IFTs (and medium/low frequency signal coils). I think I missed it out when discussing RF/IF stages in Part 2. We start off by saying that High Frequencies only flow through the "skin" of wire, not through the body of it.

There are two ways of increasing the amount of "skin" in a wire. One is to turn it into tubing, and this is done with high power transmitters but we don't have enough room in our receivers.

The second answer to this problem is to use *"litzendraht"*. As this is a German word (*"draht"* is *"wire"* in German and I suspect *"Litz"* is the name of the inventor. No doubt one of our DL members will let us know.) I'll start again – as this is a German word we make it acceptable in English by shortening it to "litz" wire.

So much for the name of it but what is it? Well, it's a conductor made up of a number of strands, each separately insulated and interwoven, and connected together in parallel at the ends. Its RF resistance is much less than the equivalent cross-section of

solid conductor.

Hence its use in tuned circuits will produce greater efficiency and narrower bandwidth. Its use was almost universal in coils wound for frequencies below about 2 Mc/s. But, and it is a big BUT, if it comes adrift the chances of a successful repair are minimal.

The soldering of litz wire has always been a black art; I've never successfully done it. Some people will tell you that the insulation can be carefully scraped off. Some will tell you that you can burn it off in an alcohol flame. Others will say you can use a "special" solvent.

Quite frankly, I've no idea which is the "magic process". When I get a broken litz coil I know it's a goner. Incidentally, this brings me to a pet theory of mine. If, say, half the ends of a litz-wound IF coil have become open circuit, the set will still work but with reduced efficiency. I wonder how many vintage radios suffer from this virtually untraceable degeneration?

Anyway; back to business, let's see what goes on with this signal after it leaves the IFT.

The top end of L1 is "hot" to RF and is connected directly to the demodulator diode. In our cct it's the RH diode anode but they're both the same. A feed is taken via C5 (20pf – 100pf) to the diode anode responsible for AVC.

The lower end of the unit is the "earthy" end RF-wise but "hot" DC and audio-wise. This means that the three voltages (one DC, one RF and one AF) have to be separated.

This is done for RF quite simply by taking C2 straight to earth. The typical value will be 100pf which is rather low compared with normal RF decoupling condensers, but it is in a high impedance circuit and it is necessary

for it not to bypass audio frequencies to any extent. R1, typically 20k to 100k, "forces" the radio frequency to earth via C2 but passes the DC and audio components down to the ganglion junction of R1, C3, C4, and R2. Let us now examine each of the three new components from this point.

C3 is another RF by-pass condenser, to get rid of any last traces of the IF which may have squeezed through R1.

R2, typically one megohm, has a twofold job. One is to present a high resistance to the recovered audio component and "force" it through C4, typically 0.01 mfd, which presents a low impedance to AF thus allowing it access to the top of R3 which is the AF gain control. This is typically 500k, but must be logarithmic in characteristic. This is because the human ear is logarithmic which means, in simplistic terms, that when the AF gain control is set at 50% of its travel the resistance (and actual AF voltage level) has only increased by 10%.

The recovered audio is then fed via a screened cable direct to the grid of the triode section of V1. At this point go back to Part One of "Duffers' Guide" and follow the rout to the loudspeaker.

R2, typically 470k, has what may seem to be a rather abstract function in this operation and I must pause now to explain another term which can often cause confusion. This is the word "delay" when used in the term "delayed AVC".

Now when I first came across it I assumed, not unnaturally, that it meant a delay in time. It usually does. But on reflection it makes no sense at all. Who would want to be deafened for ten seconds before the AVC swung into action and reduced the cacophony?

No, the term relates to a voltage delay or standing bias in the AVC. This

"delay" is used to negate the action of the AVC on weak signals and only deploying the facility when a signal reaches a reasonable strength. This is self-evident upon consideration.

And this is how it works. By a happy coincidence the cathode bias on V1, which is developed across the auto-bias resistor, R7 (say 1k or 2k), is about the value required (a volt or so). The cathode is common to the diodes as well as the triode and thus the bias will be applied to the AVC diode (the left-hand one) and cause it to be inoperative until the signal level rises above this. R2 provides half of this link.

R6 (470k) provides the other half and is the AVC diode anode load. The negative rectified (DC) carrier voltage appears at the top of R6 and is fed to the preceding amplifiers via R5 (470k) and R4 (470k). C7 (0.01mfd) ensures that the audio component is filtered from the AVC line.

The only component so far not mentioned is C6 (25mfd), the triode cathode decoupler. It is mentioned more appropriately in Part One. Its purpose in the AVC role is to ensure that no audio enters the line.

If you're confused by now, perhaps you should go back to the start and read it slowly!

Of all the items likely to cause problems in this circuit none rates higher than C7. The slightest leakage will short out the AVC and cause awful distortion on strong signals. This is a near certainty on an old valve set. Replace it.

Not shown in our mini-circuit is the continuation of the AVC line to earlier stages (anything up to five). Each will have its own equivalent of R4 and C7 to separate it from its neighbour. The same comment applies.

♣

# The Duffers' Guide to Valve Set Fault-finding – (part eight)

By Graeme Wormald G3GGL

I think we may have come to the natural end of this mini-series and I'm going to finish on a new note; aerials. But before I start I'll mention some of the comments that have come in since the last issue.

Several members have asked if the series is to be available on CDRom. The answer is that I think not. The whole run only amounts to thirty-odd pages and I would have thought this would be more convenient as a bound photocopy.

Another request was to produce a version on transmitters. This, of course, would be impossible as there is no standard pattern of transmitter from the era (*as there is of receivers*). In this field, using "Junk-Box Baby" as a primer, I would suggest that students move forward by acquiring copies of the ARRL Radio Amateur's Handbook, ideally at 5-yearly intervals from 1940 to 1960. They have been published annually without break since the nineteen-twenties.

This goes equally for the continued study of valve receivers. These manuals are "worth their weight in gold" and may be obtained for prices less than the new current edition (*which, of course, is of no help whatever to us!*).

**W**hat have aerials got to do with Valve Set Fault-finding? You may well ask, and the answer is; more than you think.

Let us first consider the aerial input and earth circuit of a "common or garden" receiver. Look at Figure "One". You will see that it has two terminals, one labelled "A" (aerial) and one labelled "E" (earth).

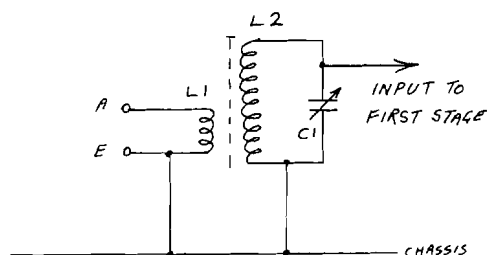

Figure "One"

The one labelled "A" goes (*via any bandswitching*) to the aperiodic (*untuned*) primary (L1) of the grid circuit of the first stage, which will be either a radio frequency amplifier or a frequency changer. (*Again, all band-switching, a.v.c. arrangements and*

*other irrelevant complexities have been omitted*).

The one labelled "E" is connected to the chassis of the set which, if a mains set (*and the sort we are speaking about are*) should be connected to the mains earth lead. (*In a 'universal' AC/DC set there are special arrangements for isolating the 'live' chassis from the 'earth', but this is entirely academic and doesn't affect the debate presented here*).

In such a set the connection of a 30 ft random wire will complete a circuit via the chassis to the mains earth (*or, in the absence of such, via stray capacity to the power wiring, which will work as a counterpoise or capacity earth*) and thus induce an R.F. (signal) voltage into the tuned circuit L2/C1. It won't be marvellous but it will work more or less equally across the bands.

Time and again Ted, myself and others have declared in these pages that most Eddystones are designed to take balanced twin feeders. Sometimes 75

ohms. Sometimes 400 ohms. At this stage it's academic. Take a look at Figure "Two", which is a simplified version of such sets as the 640, 740, 840, 940 and most numbers in between.

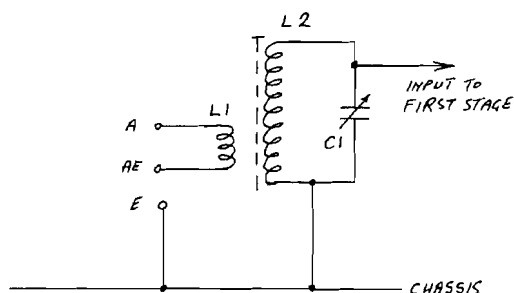

**Figure "Two"**

You will see that it has two aerial terminals, labelled A and AE, plus one labelled E. Sometimes the first two are labelled A1 and A2. It's of no matter; the set-up is just the same.

The connections to the primary aperiodic winding (L1) are coupled to A and AE (or A1/A2). These are usually of the 'binding post' variety where you press the end of the terminal which is spring-loaded. This reveals a hole through the barrel into which the end of the bare wire is pushed. The post is then released and the wire is held in firm contact.

The idea is to use a "doublet" or "dipole" aerial fed with balanced twin feeders (*stuff like 'hifi' speaker leads, which will do the job fine, or 400-ohm ladder twin feeder*). The main object of this is that the aerial may be kept well away from the set, which may be in an area of static interference.

On board ship is probably the worst case, as the 110V DC supply was produced from an incredibly 'dirty' dynamo. The arcing on the commutator would do justice to Guy Fawkes Night.

In this day and age the culprits are mainly in the house; the Computer, the

Television, associated remote controls, fluorescent lighting and so on. The twin feeders pick up neither signal nor interference.

If, on the other hand, it is desired to use a random length of wire (*which acquires its 'return path' through earth*), then AE must have a shorting link fitted to E. This then turns the sets into a Figure "One". It will work but it won't do its best.

Should the set have a 75-ohm aerial input impedance, such as the 888A, and it is desired to feed it from the main station aerial via a tuning unit, then the connection will be via co-axial cable, whatever the actual aerial feeder. In this case AE and E should also be connected.

**And now we come to the state of "Fault Condition".**

This occurs when a new owner puts an end fed random wire onto A, without the benefit of a shorting link on the AE terminal to E.

Take another look at Figure "Two". You will see that there is nowhere for the aerial current to flow through L1. In fact it is working purely by stray capacity between L1 and L2. There is no inductive coupling.

This rather inadvertent arrangement tends to favour the higher frequencies due to the reduced impedance. For instance, strong AM broadcast stations on the 19 metre band may still be well in evidence, whereas local low-powered medium wave stations may be down at S2 or 3.

And this is where the really careless Duffer will start to complain that his newly-aligned and re-valved Eddy-stone is deaf. So if you're going to run your set on an unbalanced random length of wire (*as most neophyte SWLs do!*), then check that your shorting link is in position! ♠